

J. K. KOONS.

LATHE FOR TURNING BODIES HAVING ELLIPTICAL CROSS SECTIONS.

No. 395,838.

Patented Jan. 8, 1889.

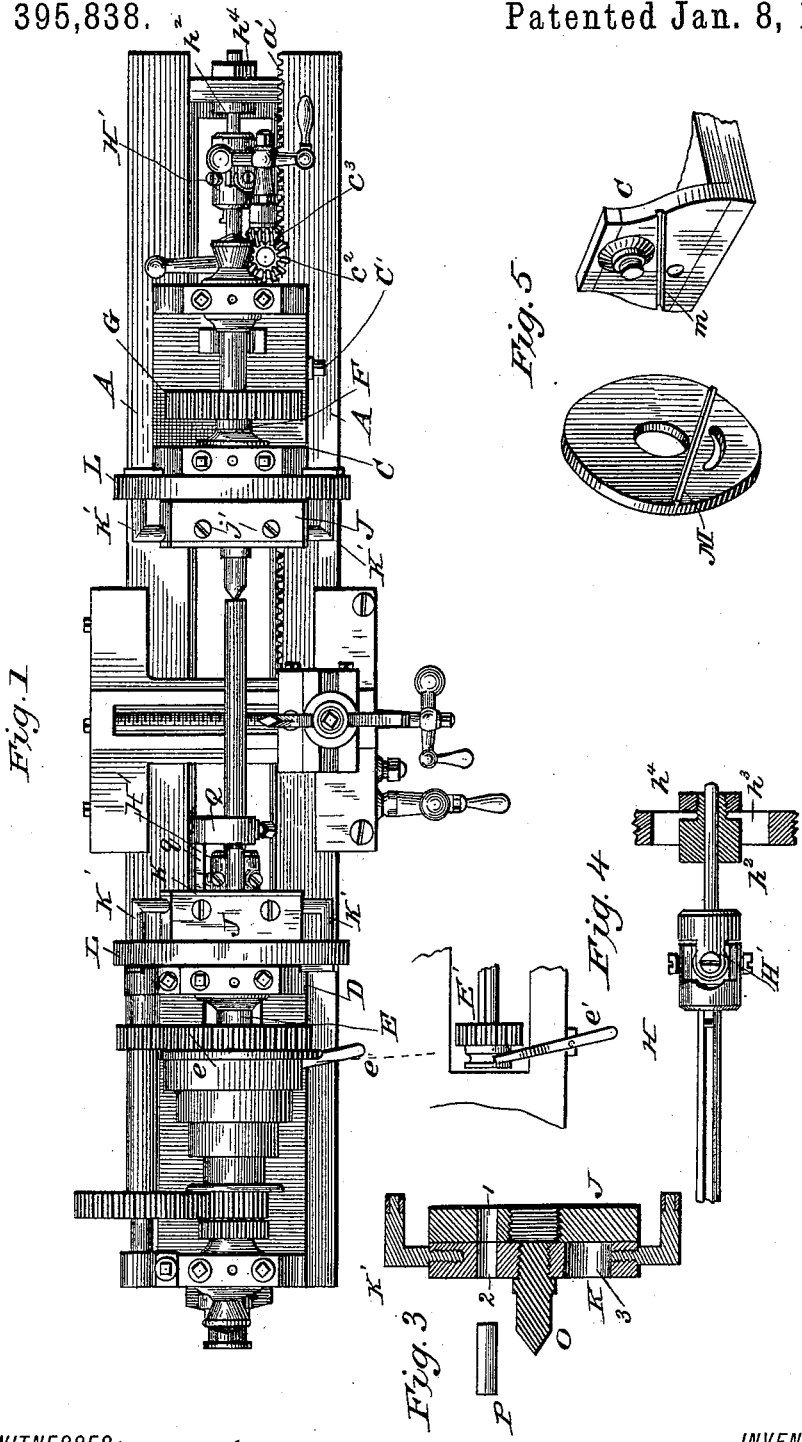

WITNESSES:
Fred G. Dieterich
P. B. Turpin.

INVENTOR.
J. K. Koons
 BY *Munn & Co.*

ATTORNEY.

UNITED STATES PATENT OFFICE.

JOSEPH K. KOONS, OF MONTGOMERY, PENNSYLVANIA.

LATHE FOR TURNING BODIES HAVING ELLIPTICAL CROSS-SECTIONS.

SPECIFICATION forming part of Letters Patent No. 395,838, dated January 8, 1889.

Application filed April 20, 1888. Serial No. 271,358. (No model.)

To all whom it may concern:

Be it known that I, JOSEPH K. KOONS, of Montgomery, in the county of Lycoming and State of Pennsylvania, have invented a new and useful Improvement in Metal-Turning Lathes, of which the following is a specification.

This invention is an improvement in metal-turning lathes, seeking especially to provide in metal-turning lathes convenient means whereby to turn ovals and oval shafting, as will be described.

The invention consists, broadly, in movable supports for the centers or work-holders, whereby the work in the operation of the lathe will be moved as it is rotated toward and from the tool.

The invention consists, further, in certain novel constructions and combinations of parts, as will be hereinafter described and claimed.

In the drawings, Figure 1 is a top plan view of my lathe. Fig. 2 is a front elevation thereof, parts being broken away and others shown in section. Fig. 3 is a detail sectional view of one of the work-holding devices and some of the adjusting means therefor. Fig. 4 is a detail view of a part of the connecting-shaft and its adjustable end bearing. Fig. 5 is a detail view illustrating the manner of connecting the guide-bearing plate on one of the lathe-stocks. Fig. 6 is a detail view, partly in section, on about line *x x*, Fig. 2. Fig. 7 is a sectional view on about line *y y*, Fig. 2; and Fig. 8 is a detail face view of one of the work holding and adjusting devices.

In carrying out the invention the lathe-bed is formed with suitable shears, A A, for the tool-carriage and tail-stock, and has racks *a a'* for engagement by the rack-pinions *b c* of the carriage B and tail-stock C, the tool-carriage being constructed and arranged for operation in the ordinary way, and therefore requiring no further description.

The head-stock D is supported on the bed, and is provided with the spindle E, which may be geared up and driven in the usual manner. The tail-stock C supports the spindle F, which has a gear-wheel, G, geared with a pinion, *h*, keyed on the connecting-shaft H, which connecting-shaft has also a pinion, *h'*, geared with a gear-wheel, *e*, on the spindle E, preferably through the intervention of a connecting-pinion, E', which is movable by the aid of a lever, *e'*, into and out of mesh with

the gear E, so that the tail-stock may at will be thrown out of gear, as may be desired, when the lathe is being used for turning circles. As the spindle-carrying portion of the tail-stock can be adjusted laterally by means of a screw, C', in the usual manner, I form the connecting-shaft H in sections, united by universal joints or couplings H', and connect the sections of such shaft at the tail-stock end of the bed or frame adjustably to said frame, so that it can be adjusted laterally when desired. This lateral adjustment is secured by passing the end section of shaft H through a box, *h²*, movable in a slot, *h³*, in the end plate of the bed-frame, and fitted to receive a securing-nut, *h⁴*, so that the shaft-section may be set laterally and secured as desired. By the described construction the two spindles are geared together, so that they will be rotated accurately together, and means are also provided for throwing the tail-stock spindle out of gear when desired to turn circles or when it is desired to use a chuck instead of a center on the live-stock spindle. In adjusting the tail-stock along the shears I prefer to provide a shaft, *c'*, carrying the pinion *c*, meshing with the rack *a'*, and also having a bevel-pinion, *c²*, meshed by a bevel-pinion, *c³*, on a short counter hand-shaft, *c⁴*.

The head-stock is pivoted to the lathe-bed at I, so that the said stock may be turned to different angles for the purpose of turning or boring tapers. In order to secure the head-stock in any suitable adjustment on pivot I, I provide a screw, *i*, turning through a slot, *i'*, in the bed-frame into the head-stock at the outer end of the latter, such screw forming a clamp by which to hold the head-stock as desired.

The work-carrying devices and the means for adjusting them being the same on both spindles, the description of one will answer for both.

On the inner end of the shafts I secure, usually by threading, as shown, a block or head, J, and the block or plate K, forming the support for the work-holder, slides in said head J in a direction radial to the spindle. By preference the plate K has a dovetail rib fitting a proper groove in the head J, a gib, *j*, and set-screws *j'* being provided, whereby the plate K may be secured snugly in the groove or way in the said head. By moving the supports K radially to the spindles as the latter

are rotated it will be seen that the work secured by the work-holders carried by said supports will be made to describe an irregular as distinguished from a true rotary motion. To effect this movement of the supports, I provide at their outer ends arms or portions K' , which enter true circular guide-grooves l in plates L , supported on the head and tail stocks, such grooves l forming guide-bearings. These plates are preferably secured adjustably to the stocks by forming ribs M on one of the said parts to enter grooves m in the other, as shown, and bolts N being provided for securing the said guide-plates L in their different adjustments. In the construction shown the guide-plates L are designed for use in turning ovals, and their bearings or grooves l are true circles, and the plates may be adjusted to vary the form of the oval. It is manifest, however, that the plates L might be stationary and have their guide-grooves formed circular and eccentric to the center of motion of the spindles to properly guide the work-holder support to serve in forming a given oval; but I prefer the construction shown.

The work-holder shown is a common center, O , which is in the present instance removable, and may, if desired, be replaced by an ordinary chuck on one or both of the spindles. It will be understood that a chuck when used would ordinarily be used on the live or head-stock spindle only, and such spindle be thrown out of gear with the tail-stock spindle, if desired.

In operation, when work is supported between both spindles and the latter are both turned, the guide-plate L and work-holders and supports having been properly adjusted, the work will be moved with reference to the tool to properly turn the oval, and an oval shaft may be turned of any length capable of being supported between the stocks of the lathe. It will also be understood that work may be held in suitable chucks on the spindle of the head-stock and the latter be turned on pivot I , and the movable work-holder support and its operating means be set so that an oval taper may be bored in or turned on said work. It will also be understood that the plates L and work-holders and supports may be removed from the spindles and ordinary face-plates be secured in place thereof.

In order that the plates J and K may be prevented from any independent movement when it is desired to turn circles, I provide them with coincident openings $1\ 2$, into which a pin, P , may be placed. The plate K also has a slot, 3 , to receive the tail q of carrier Q .

Having thus described my invention, what I claim as new is—

1. The combination, in a lathe, of the two spindles, one of which is movable laterally with reference to the other, the movable work-holders connected therewith, and the gearing and connecting-shaft between said spindles, such shaft being formed in sections united

by universal couplings, substantially as set forth.

2. The combination, in a lathe, of the two spindles, the head-stocks supporting same, one of said head-stocks being movable laterally with reference to the other, the bed-frame, and the gearing and connecting-shaft connecting said spindles, such shaft being formed in sections and having its end section supported adjustably in the framing, substantially as set forth.

3. In a turning-lathe, the combination of the spindle, the head J , secured thereon, the plate K , held and movable in a groove in said head J and having a portion or arm, K' , and a plate, L , having a groove to receive said portion, the parts $J\ K$ being provided with openings $1\ 2$, movable into register and adapted to receive a securing-pin, substantially as set forth.

4. In a turning-lathe, the combination of the bed-frame having a rack, a' , the tail-stock C , the shaft c' , journaled thereto and having a pinion, c , engaging rack a' and a bevel-gear, c^2 , and the counter-shaft c^4 , having a bevel-pinion, c^3 , substantially as set forth.

5. In a turning-lathe, the combination of the bed-frame, the head and tail stocks thereon, one of such stocks being adjustable laterally with reference to the other, the spindles and guide-plates supported by said stocks, the work-holder supports on said spindles and provided with studs or portions arranged to engage the guide-plates, and the gearing and connecting-shaft connecting such spindles, such shaft being formed in sections and having its end section supported adjustably in the framing, substantially as set forth.

6. The combination of the head supported on the spindle and provided with a dovetail groove, the work-support having a rib fitting said groove, the gib j , and set-screw j' , all substantially as and for the purposes specified.

7. In a turning-lathe, the combination of the head supported on the spindle, the support K , provided with the spindle O and having a slot, 3 , fitted to receive the tail of a carrier, such support being movable radially and provided with a stud or projecting portion, and guides arranged for engagement by said stud or portion, substantially as set forth.

8. The combination, in a turning-lathe, of the bed-frame, the two head-stocks, one of said head-stocks being adjustable laterally with reference to the other, the spindles in said head-stocks, the gear-wheels in said spindles, the connecting-shaft formed in sections united by universal joints, and the pinions on the said shaft, one of said pinions being movable along the shaft, all substantially as and for the purposes specified.

Witnesses: JOSEPH K. KOONS.

C. L. THOMAS,
P. B. TURPIN.